

HZ-100-G Series

HZ-100-G-M Monochrome

HZ-100-G-C Color



103.7MP 100GigE camera with Gpixel GMAX32101 CMOS sensor

HZ-100-G features the Gpixel GMAX32103 CMOS sensor. At full resolution (11276 x 9000), you get 24 frames per second in 8-bit mode. Its ultra high-speed QSFP28 - 100GigE interface offers many benefits including low-cost accessories, low CPU overhead, low latency, low jitter, and accurate multi-camera synchronization using IEEE1588. In addition, QSFP28 - 100GigE offers three supported cabling options for cable lengths from 1M to 10KM.

Benefits

- » High-speed QSFP28 - 100GigE interface
- » 100x the speed of GigE
- » Ultra high data/frame rates
- » GigE Vision® and Genicam™ compliant

Applications

- » Virtual reality
- » Goal Line technology
- » Volumetric capture
- » Motion capture
- » Immersive 3D Content
- » Finish Line Vision
- » Referee Assist
- » Flat Panel Inspection
- » Machine Vision

Specifications

Sensor	GMAX32103
Resolution	11276 x 9200
Megapixels	103.7 MP
Sensor Type	46.5mm CMOS
Max Frame Rate	24 fps @ 8-bit 24 fps @ 10-bit
Cell Size	3.2µm x 3.2µm
Standard Mount	M60Mount, EF/F Mount Available
Shutter	Global
Bit Depth	8 & 10 Bit
GPIO / Triggering	3 in, 3 out Software, External (Pulse or Edge)
Interface	QSFP28 - 100GigE
Exposure/Integration*	1µs - 1s
Dynamic Range	>66db
Monochrome Modes	Mono8, Mono10
Raw Modes	BayerGB8, BayerGB10
Operating System	Win10 (64 bit), Linux (64 bit)
Compliance	CE, FCC, RoHS, WEEE, GigE Vision, GenICam
Power Requirements	18W, 12V
Operating Temperature	0C - 45C
Storage Temperature	-30C to +60C
Dimensions & Weight	97 x 66 x 73 - 750g
Warranty	2 Years

*all minimum exposure specs can vary from what is listed based on the limitations of each sensor as per notice from the manufacturer.

*fanless and IP67 options available. Please contact your sales representative for details.

Mechanical drawings

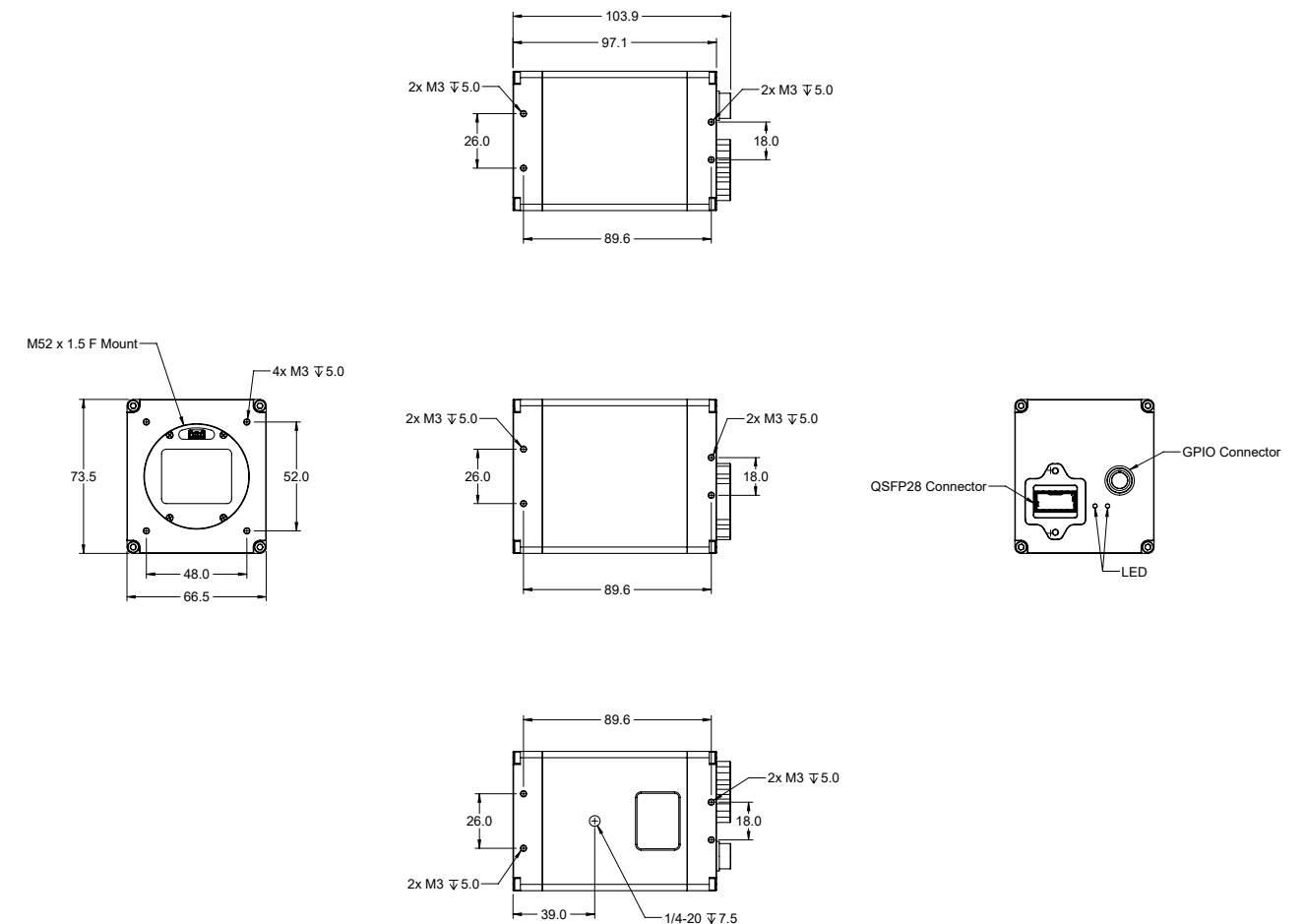

Any Questions?

1-866-780-6082
 sales@emergentvisiontec.com
<https://emergentvisiontec.com>